

A-A

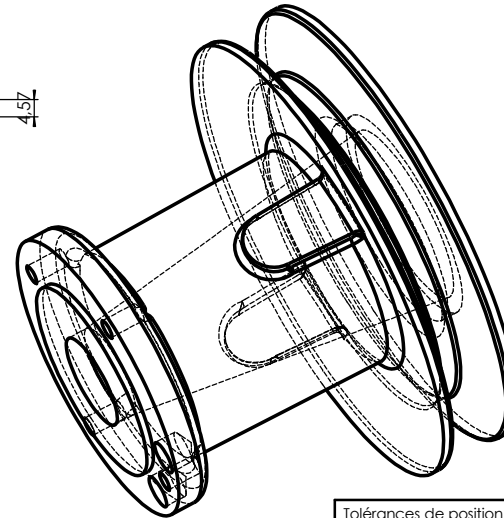
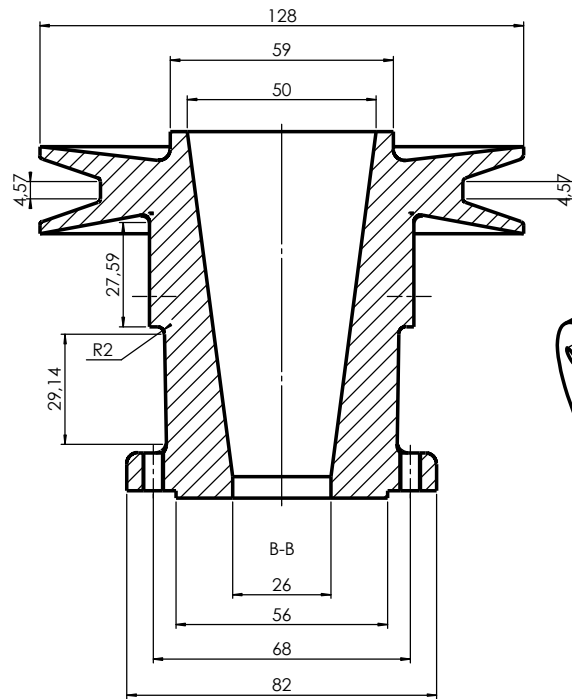
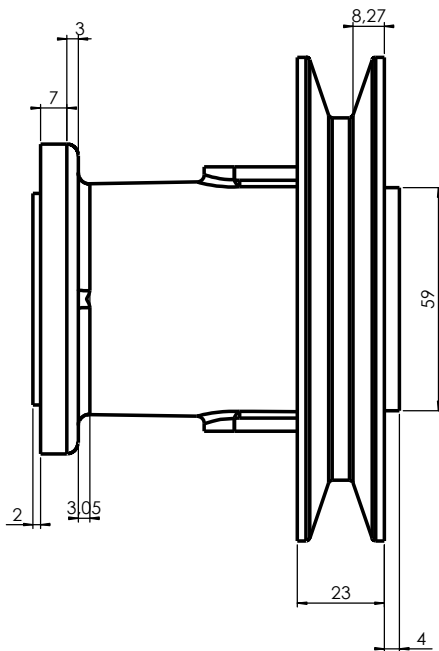

|   |                |          |           |                     |                |                                     |
|---|----------------|----------|-----------|---------------------|----------------|-------------------------------------|
| Tolérances de position                      | // 0.1 mm      | ⊥ 0.4 mm | ◎ 0.02    | ⊕ 0.15              | Tol. Gen. Js11 | Ch. ou Ray. 0.2 à 0.5               |
| Etat de surface Gen.= 3.2                   | Tolérance brut |          | ∠ 0.25 mm | Tolérances de forme |                | ∇ 0.1 mm / 0.04 mm                  |
| Nb: 1                                       | Matière: ALU   |          |           |                     |                | N° 19067                            |
| Désignation pièce: poulie ventilateur       |                |          |           |                     |                | Ech: 1/1                            |
| Désignation ensemble: Moteur SALMSON 2300 S |                |          |           |                     |                | Nom: MARGERIN_O<br>Date: 18/01/2004 |
| Code client: Code client:                   |                |          |           |                     | A2             |                                     |